

Ref. : DI7140.pas

Rev. : B

Date : 21/07/09

Page : 1/1

RUBBER EXPANSION JOINT BSPT FEMALE THREADED

DI 7140



ROBINETTERIE INDUSTRIELLE ET ACCESSOIRES
INDUSTRIAL VALVES AND ACCESSORIES

APPLICATION

Expansion joint.

GENERAL CHARACTERISTICS

EPDM rubber bellow
Female cast iron 3 piece BSPT threaded union ends galvanized cast iron.

Movement:

- Axial compression,
- Axial elongation,
- Lateral movement.

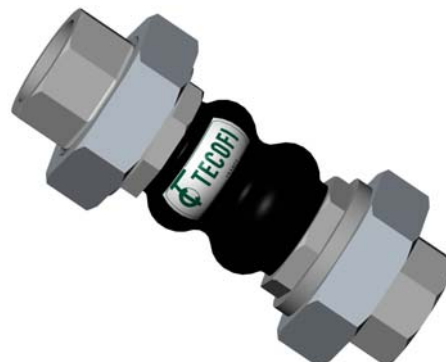

CONSTRUCTION

3	2	Union	Galvanized cast iron
2	1	Reinforcement	Nylon tyre cord
1	1	Bellow	EPDM rubber
Pos.	Qty.	Description	Material

DIMENSIONS

DN		L	Lc	Le	LI	A°	Weight (kg)
mm	inch						
15	1/2"	203	22	6	22	32°	0,43
20	3/4"	203	22	6	22	32°	0,65
25	1"	203	22	6	22	25°	1,12
32	1"1/4	203	22	6	22	25°	1,45
40	1"1/2	203	22	6	22	20°	1,90
50	2"	203	22	6	22	15°	2,52
65	2"1/2	240	22	6	22	12°	3,58
80	3"	240	22	6	22	10°	5,15

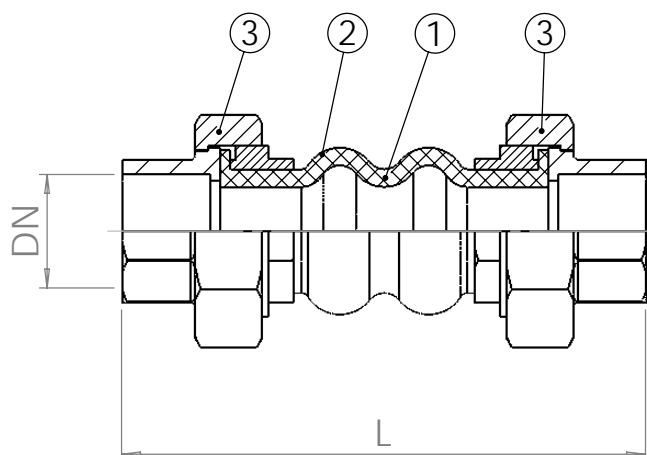

Lc : Axial compression.

Le : Axial extension.

LI : Lateral movement.

WORKING CONDITIONS

Maximum working pressure : 10 bar.
Maximum temperature : - 10°C / + 110°C.

Pressure test according to standards
EN 12266-1, DIN 3230, BS 6755 and ISO 5208.

STANDARDS

BSPT female threaded according to standard
ISO 228-1.

